



## **ZONING PERMIT APPLICATION PACKET**

### **Submission Checklist**

- Application completed in ink and signed by **applicant and property owner** if the applicant is not the property owner or provide written authorization from the owner to act as their agent.
- Completed plot plan with all required information attached, please refer to sample provided (Applications will not be reviewed until a complete plot plan is submitted)
- Building Plans/Permit Application, as applicable. Include a floor plan and elevation plan for all new construction, including additions and other required structures. (The building plans must be consistent with the submitted plot plan) – Building plans will not be submitted to the Third Party UCC building inspection company for review until an approved zoning permit is issued.
- Impervious Coverage Percentage for new accessory or primary structures and/or additions to primary structures (impervious coverage divided by lot area)
- Pennsylvania Contractor License and Cert. of Insurance if property owner is not performing work.
- Height and size of structure specified on application where indicated.
- Parcel ID number and property address (<https://gis.ccpa.net/propertymapper>)
- Contact person, phone number, and e-mail address
- Copy of recorded deed (if required)
- Copy of Driveway Permit (if required)
- Highway Occupancy Permit (if required)
- County Conservation District Approval (if required)
- Copy of Storm Water Approval/Permit (if required)
- Copy of Elevation Certificate (if required)

## General Requirements

**If you are proposing a change to the property which will require a new point of access (such as a driveway or curb cut), you will need to secure approval for access into the adjoining road or street:**

- If the road is a state highway you will need to secure approval of a highway occupancy permit from PennDOT and provide a copy to the Borough.
- If the road is a Borough Road, you will need to secure approval of a curb and sidewalk permit from the Borough prior to obtaining a zoning permit.

**The payment for the Zoning Application is a separate payment from the Building Permit. Any additional zoning fees due are payable to New Cumberland Borough upon issuance of the permit.**

**Applications must be completed in ink. Return the original completed application and application fee along with all applicable documents to New Cumberland Borough.**

**If you are grading/excavating or filling a site, provide the following information: Area of:**

Excavation (sq. ft.) \_\_\_\_\_

Fill (sq. ft.) \_\_\_\_\_

Type of Fill Material \_\_\_\_\_

Depth at deepest point of either fill or excavation (ft.) \_\_\_\_\_

Proposed Times of Operation (day, start time, finish time) \_\_\_\_\_

**If you are proposing an earth disturbance activity that involves one (1) acre or more, an erosion and sediment control plan will be required for the project that will need to be reviewed and deemed adequate by the Cumberland County Conservation District prior to commencing any earth disturbance activity.**

#1-INITIAL \_\_\_\_\_ OVER ONE (1) ACRE OF EARTH DISTURBANCE.

#2-INITIAL \_\_\_\_\_ UNDER ONE (1) ACRE OF EARTH DISTURBANCE.

**IF #1 IS INITIALED NO BUILDING OR ZONING APPLICATION WILL BE ACCEPTED BY THE BOROUGH WITHOUT PROPER CONSERVATION DISTRICT DOCUMENTATION.**

**\*\* OFFICE USE ONLY \*\***

Date Received: \_\_\_\_\_

Zoning District: \_\_\_\_\_

Tax Parcel No.: \_\_\_\_\_

Zoning Permit No.: \_\_\_\_\_

**APPLICATION FOR ZONING PERMIT**

Application is hereby made for a permit in conformity with requirements of the Pennsylvania Municipalities Planning Code, Current Local Zoning Ordinance, and any amendments thereto for the following described work:

**I. PROPERTY INFORMATION**

Residential

Non-Residential

Tax Parcel ID: \_\_\_\_\_ Development: \_\_\_\_\_

Proposed Work Site Address: \_\_\_\_\_

Lot Width: \_\_\_\_\_ Lot Depth: \_\_\_\_\_ (Acres or Sq.ft.)

Lot Size: \_\_\_\_\_

Property within Floodplain  Yes  No If Yes, Complete next line

Do you have an elevation certificate  Yes  No If Yes, please attach a copy with submission

Current Use of Property: \_\_\_\_\_

**II. CONTACT INFORMATION**

**Applicant:** \_\_\_\_\_ email: \_\_\_\_\_

Mailing Address: \_\_\_\_\_ City: \_\_\_\_\_ State: \_\_\_\_\_ Zip: \_\_\_\_\_

Phone: \_\_\_\_\_ Phone: \_\_\_\_\_ Fax: \_\_\_\_\_

*(If different than Applicant)*

**Property Owner:** \_\_\_\_\_ email: \_\_\_\_\_

Mailing Address: \_\_\_\_\_ City: \_\_\_\_\_ State: \_\_\_\_\_ Zip: \_\_\_\_\_

Phone: \_\_\_\_\_ Phone: \_\_\_\_\_ Fax: \_\_\_\_\_

**Contractor:** \_\_\_\_\_ email: \_\_\_\_\_

Mailing Address: \_\_\_\_\_ City: \_\_\_\_\_ State: \_\_\_\_\_ Zip: \_\_\_\_\_

Phone: \_\_\_\_\_ Phone: \_\_\_\_\_ Fax: \_\_\_\_\_

**III. CONSTRUCTION**

**Erect a Structure**  Principal  Accessory **Size** (length, width and height) i.e., 20' L, 15' W, 12' H: \_\_\_\_\_

**Add to a Structure**  Principal  Accessory **Size** (length, width and height) i.e., 20' L, 15' W, 12' H: \_\_\_\_\_

**Change of Use** Existing: \_\_\_\_\_ Proposed: \_\_\_\_\_

**Erect a Fence** Height: \_\_\_\_\_ (feet) Type of Fence: \_\_\_\_\_

**Install a Patio** Size (length, width, and height) i.e., 20' L, 15' W \_\_\_\_\_

**Off-street Parking Area or Parking Lot**

**Install a Swimming Pool**  In-ground  Above-ground

**Establish a Home Occupation** Description: \_\_\_\_\_

**Other** please specify: \_\_\_\_\_

**IV. PROJECT DESCRIPTION** Provide a narrative which explains the proposed project based upon the items checked in the previous section (III)

Cost of Construction: \_\_\_\_\_ Street Access:  Municipal  State  Other  
 Sewage Disposal:  Public Sewer  On-Lot Water Supply:  Public Water  Well

**V. PLOT PLAN**

**PLEASE INCLUDE THE FOLLOWING:**

1. Indicate the length of all property lines
2. Show all existing and proposed structures on property and the distance from the structure to the property lines
3. Indicate name of streets abutting property
4. Identify all bodies of water and show distance to proposed structure(s)
5. Show septic, well, driveway locations and distance from new structure to septic
6. Label distances from principal structure to proposed accessory structure(s)

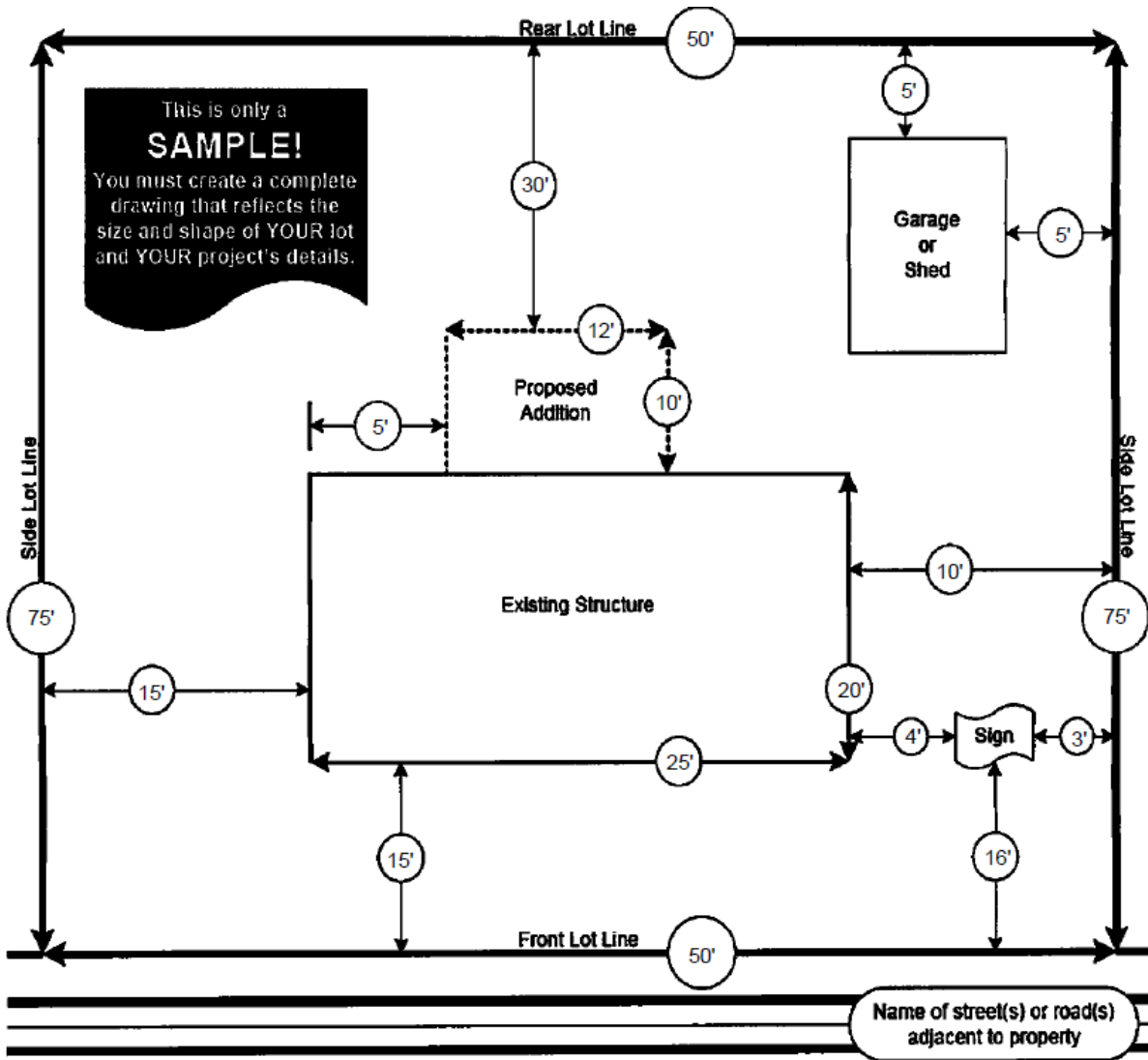

**IMPERVIOUS COVERAGE**

Proposed: \_\_\_\_\_ (Sq.ft.)

Existing: \_\_\_\_\_ (Sq.ft.)

Address: \_\_\_\_\_

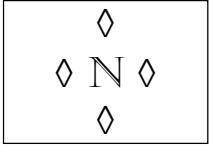

**PLOT PLAN**

*\* A survey or other prepared plot plan can be attached, in lieu of this sketch sheet.*

Approved by: \_\_\_\_\_

Date: \_\_\_\_\_ Permit No.: \_\_\_\_\_

I hereby authorize the Borough Staff to perform inspections related to this application as may be required between the hours of 8 AM and 5 PM. The applicant understands and agrees to comply with the Pennsylvania Municipal Planning Code and Zoning Ordinance, as amended. All information supporting this application shall become part of the records of the Borough, cannot be returned and may be examined by the public at any time during the normal working hours of the Borough Office.

Application is hereby made for a permit to erect or alter a structure which shall be located as shown on the attached diagram/plot plan and/or to use the premises for the purposes herewith. The information which precedes, together with the plot plan/diagram, is made part of this application by the undersigned. It is understood and agreed by the applicant that any error, misstatement or misrepresentation of material, fact, either with or without intention on the part of this applicant, such as might or would operate to cause a refusal of this application or any change in the location, size or use of structure or land made subsequent to the issuance of this permit without approval of the Zoning Officer, shall constitute sufficient ground for the revocation of this permit.

**Applicant Signature:** \_\_\_\_\_

**Date:** \_\_\_\_\_

**Owner Signature:** \_\_\_\_\_

**Date:** \_\_\_\_\_

**BOTH SIGNATURES ARE REQUIRED IF APPLICANT IS DIFFERENT THAN OWNER**

**\*\* OFFICE USE ONLY \*\***

**Meeting Dates (if applicable)**

Planning: \_\_\_\_\_ Approved:  Yes  No Other: \_\_\_\_\_

\_\_\_\_\_ Approved:  Yes  No

**PA UCC Construction Permit Required:**  Yes  No

**Action Taken:**  Approved  Denied

Zoning Fee: \_\_\_\_\_

Application Fee Paid: \_\_\_\_\_

Balance Due: \_\_\_\_\_

Date Paid: \_\_\_\_\_

**Zoning Officer Signature:** \_\_\_\_\_

**Date:** \_\_\_\_\_

If the permit is denied, the zoning officer shall note the applicable sections/basis of denial below:

\_\_\_\_\_  
\_\_\_\_\_  
\_\_\_\_\_  
\_\_\_\_\_

A copy of the zoning officer's official letter of denial shall be attached to this application.